

UM10406

SSL1523 high power factor 5 W LED driver for universal mains

Rev. 01 — 3 August 2010

User manual

Document information

Info	Content
Keywords	SSL1523, SSL152x family, LED driver, mains supply, AC/DC conversion
Abstract	This user manual describes a demonstration (demo) board for a mains operated non-dimmable 5 W LED driver using the SSL1523 SMPS controller IC.



Revision history

Rev	Date	Description
01	20100803	Draft version

Contact information

For more information, please visit: <http://www.nxp.com>

For sales office addresses, please send an email to: salesaddresses@nxp.com

1. Introduction

WARNING

Lethal voltage and fire ignition hazard



The non-insulated high voltages that are present when operating this product, constitute a risk of electric shock, personal injury, death and/or ignition of fire.

This product is intended for evaluation purposes only. It shall be operated in a designated test area by personnel that is qualified according to local requirements and labor laws to work with non-insulated mains voltages and high-voltage circuits. This product shall never be operated unattended.

1.1 General description

The SSL1523 5 W LED driver is a high performance solution for a professional non-dim-mable application with multiple high power LEDs, that requires galvanic isolation and a safe output voltage. It can generate a regulated output current with an output power of up to 5 W, which is equal to a 25 W incandescent lamp (at 63 Lumen/W). Examples are shelf lighting, down lighting, LED lighting for bathrooms etc. This device can also be used with less external components in an application, if some performance compromises can be accepted. Details of a solution with less external components are given in the application note AN10925.

2. Specification

[Table 1](#) shows the specification for the SSL1523 5 W LED driver.

Table 1. Specification

Parameter	Specification	Comment
AC line input voltage	100 V (AC) to 254 V (AC)	board has been optimized for 230 V (AC) or 120 V (AC) $\pm 10\%$ variation
Output voltage (LED voltage)	19 V (nominal): 12 V to 25 V range	-
Output voltage protection	33 V (DC)	-
Output current (LED current)	200 mA up to 250 mA	adjustable with potentiometer
Input voltage/load current dependency	$\pm 1\%$ in the range 100 V (AC) to 130 V (AC) $\pm 1\%$ in the range 210 V (AC) to 254 V (AC)	the maximum output power is not exceeded
Output voltage/load current dependency	$\pm 4\%$ /Volt in regulated range	the maximum output power is not exceeded; see graphs Figure 9 and Figure 10 .
Current ripple	$\pm 75\text{ mA} \pm 30\%$	at 250 mA
Maximum output power (LED power)	5 W	at $V_{out} = +19\text{ V}$
Efficiency	$>80\%$	at $T_{amb} = 25\text{ }^\circ\text{C}$, $V_{out} = +19\text{ V}$; see graphs Figure 11 and Figure 12 .
Power Factor:		
120 V (AC)	0.98	at 5 W output power; 19 V, $V_{out} = +19\text{ V}$
230 V (AC)	0.90	
Switching frequency	90 kHz to 110 kHz	-

Table 1. Specification ...continued

Parameter	Specification	Comment
Board dimensions	50 mm × 86 mm × 1.6 mm	-
Operating temperature	0 °C to 85 °C	-
Isolation voltage	± 4 kV	between the primary and secondary circuits

3. Demo board views

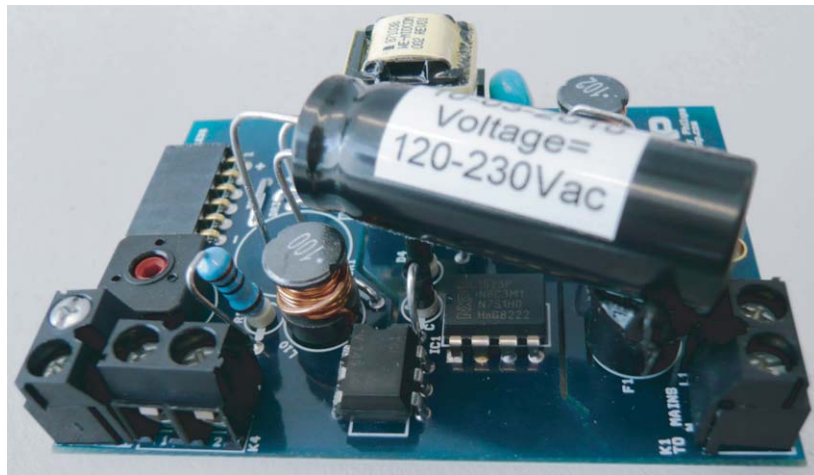

019aaa132

Fig 1. Demo board top

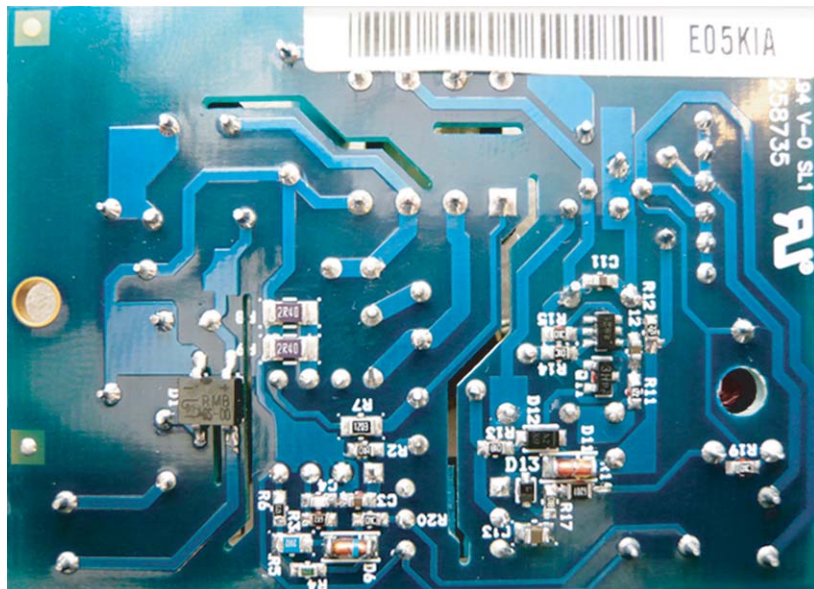

019aaa133

Fig 2. Demo board bottom

4. Demo board connections

The demo board can be operated from mains voltages of 120 V (AC) (60 Hz) up to 230 V (AC) (50 Hz). The board is designed to work with multiple high power LEDs with a total working voltage of 12 V to 25 V. The output current can be set by resistor R18, see [Section 7](#). A dedicated LED load connected to K3 can be supplied on request. The connector K2 can be used to attach other LED loads. The output voltage is limited to a maximum of 33 V. When attaching a LED load to an operational board (hot plugging), an inrush peak current will occur due to discharge of capacitor C10. After (some) discharge(s), the LEDs may deteriorate and/or become damaged.

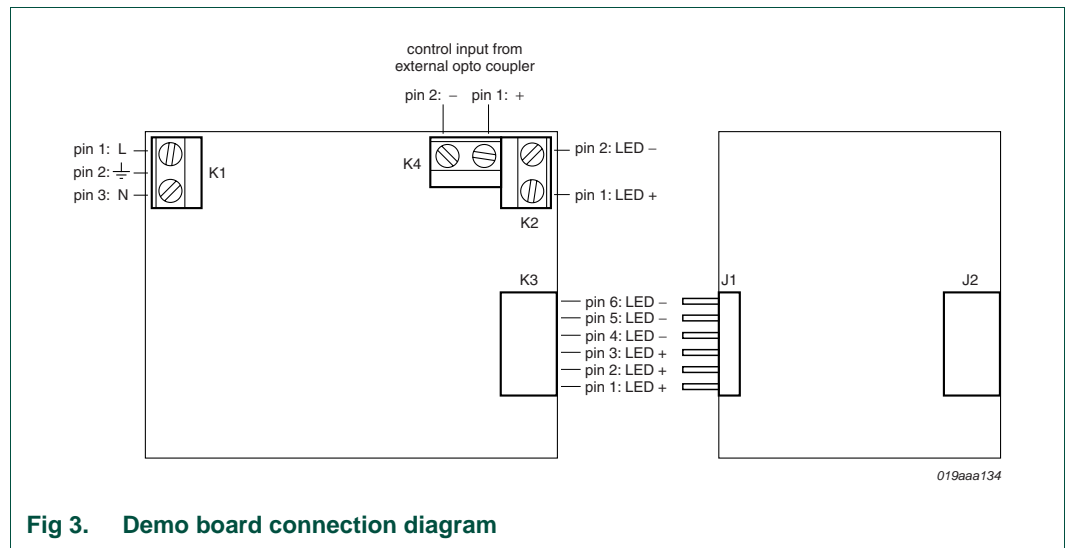

Fig 3. Demo board connection diagram

4.1 Connecting the demo board:

- If a galvanic isolated transformer is used, this should be placed between the AC source and the demo board.
- Connect a user-defined LED (string) to the connector K2 as shown in [Figure 3](#). Make sure that the anode of the LED (string) is connected to + (bottom side of this connector).

5. Functional description

The SSL1523 IC ([Ref. 3](#)) has several internal functions which include the following:

- The SSL1523 controls and drives the flyback converter.
- Over Current Protection (OCP) of the internal FET at 0.5 V on the SOURCE pin.
- The converter frequency is set with an internal oscillator, the timing of which is controlled by external RC components on pin RC.
- The REG pin controls the on-time of the internal switch between 0 % and 75 %.

This board is optimized to operate at a power factor of 0.9 in the nominal application with six LEDs on the output. In order to achieve this, the converter operates dominantly at a constant t_{on} mode. The output power of the converter is buffered by capacitor C10, and therefore the circuit exhibits resistive input current behavior (see [Figure 4](#)).

The input circuit of the converter must be equipped with a filter that is partially capacitive, in order to address the EMC requirements (see [Figure 5](#)). The combination of C1, L1 and C2 make a filter that blocks most of the disturbance generated by the converter input current. This filter is designed to have a limited capacitive load, so a good power factor can be achieved. For this design, two 150 nF capacitors are incorporated, resulting in a power factor of at least 0.9 for the nominal condition with six LEDs connected at 5 W output power.

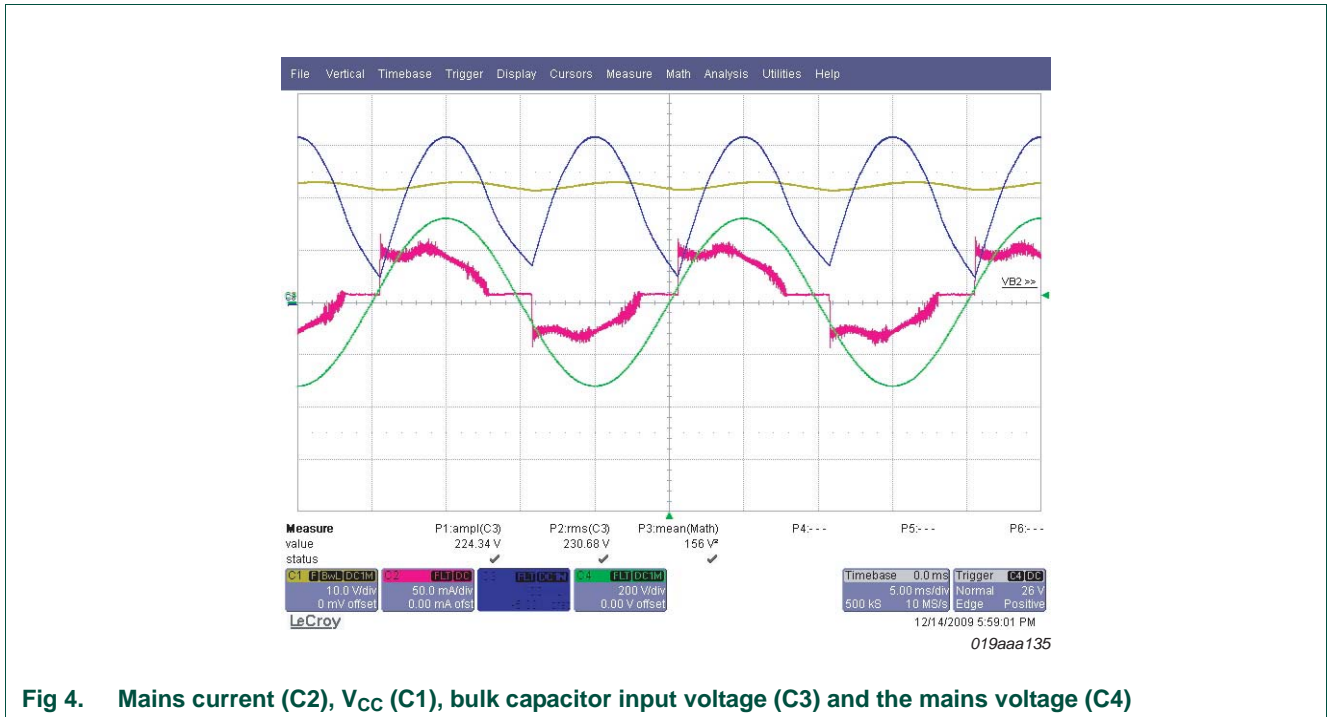

Fig 4. Mains current (C2), V_{CC} (C1), bulk capacitor input voltage (C3) and the mains voltage (C4)

The board is equipped with a feedback loop to regulate the output current. This feedback loop senses the LED current over sense resistor R10, and a current mirror is made from transistors Q10a/Q10b. Using R18, the current level can then be set. The same feedback loop is also used to provide overvoltage protection. If the LED voltage exceeds 33 V, a current through R17 and D11, D12 and D13 will start running. The current through the opto coupler IC2 will pull up the REG pin. At values above 2.7 V, the 'on time' of the internal MOSFET is zero. The feedback loop has a proportional, and partially integrated action. The gain is critical due to the phase shift caused by the converter and the output capacitor C10. Increased gain will make the feedback loop intrinsically unstable.

The accuracy of the resulting output current will satisfy the requirements of the majority of the 5 W LED applications with four to eight LEDs connected in series. The demo board can be controlled by connecting the floating output of an external opto coupler (TCDT1124 or equivalent) to K4.

The demo board can be switched on and off by switching the external opto coupler. Controlling the LED current is another option. The LED current can be regulated by applying a PWM signal to the external input with a frequency up to 1 kHz. The PWM frequency can be synchronized with the ripple frequency on the buffer capacitor C1 for an optimal mains input current shape.

6. Board system optimization

To meet specific customer application requirements, the modifications described in the following sections are possible.

6.1 Changing the output current and LED current

One of the major advantages of a flyback converter over other topologies, is its suitability for driving LED configurations with a broad range of voltages. Essentially, changing the winding ratio whilst maintaining the value of the primary inductance, will shift the output working voltage accordingly. Part of the efficiency of the driver is linked to the output voltage. A lower output voltage will require increased transformation ratio, and will cause higher secondary losses. In practice, a mains operated flyback converter will have an efficiency > 80 % for high output voltages (like 40 V) down to 50 % for very low output voltages < 3 V. At low voltages, synchronous rectification becomes advisable to reduce rectification losses.

The NXP TEA 1761/TEA1762 can be used for this purpose, see [Ref. 1](#). For exact calculations of transformer properties and peak current, refer to [Ref. 2](#) application note AN10754, "How to design an LED driver using the SSL2101", see [Ref. 2](#).

6.2 Changing the output ripple current

The output ripple current is mostly determined by the LED voltage, the LED dynamic resistance and the output capacitor. The present value of C10 has been chosen to optimize the capacitor size under typical load. The resulting ripple of ± 30 % will result in an expected deterioration of light output < 1 %.

The size for the buffer capacitor (C10) can be estimated from [Equation 1](#):

$$C_{10} = \frac{I}{\Delta I} \cdot \frac{1}{2\pi f_{net} \cdot R_{dynamic}} \quad (1)$$

Using a series of LEDs, the dynamic resistance of each LED can be multiplied by the number of LEDs. The current sense resistor (R10) should also be included in this calculation.

Example: For a ripple current of ± 30 %, and a mains frequency of 50 Hz, and a total dynamic resistance of 7 Ω, the resulting capacitance value will be 3.3333 / (314*7) = 1500 μF. The capacitor must be specified for the HF switching related ripple current of about 0.35 times the average effective LED current (I_{LED(AV)}). For high lifetime applications, the ripple current specification of the electrolytic capacitor must be increased. For details, please contact the capacitor supplier.

6.3 Changing the load curve

The current load curve can be divided into the following two regions:

- Where the current control loop regulates the output current, the constant current output
- Where the IC limits the peak input current of the converter, the constant power output

The constant power output occurs at output voltages above 23 V combined with an output power exceeding 5 W, see also [Section 9](#), [Figure 9](#). In this area, constant output power becomes the dominant control mechanism. At very low output voltages, the feedback loop will become non-functional, resulting again in constant output power mode. An output short-circuit will cause an output current of about 1 A, resulting in increased stress on the transformer TX1, shunt resistor R10, the output diode D10, and the snubber diode D3.

7. Board schematic

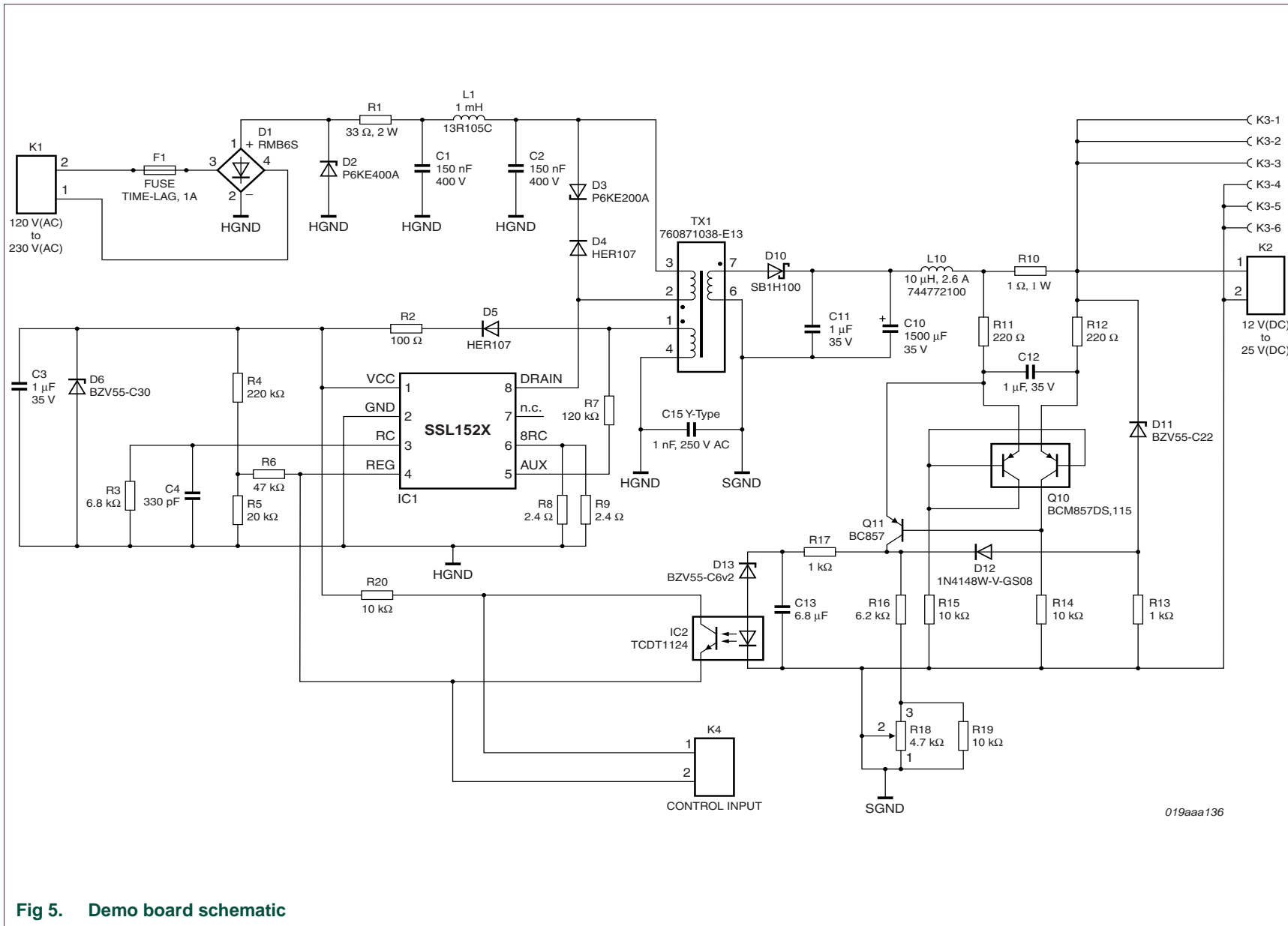

Fig 5. Demo board schematic

7.1 Bill of materials (BOM)

Table 2. Bill of materials

Part no.	Description	Value	PCB footprint	Supplier	Art no.	Manufacturer	Manufacturer part no.
C1	capacitor	150 nF 400 V	-	Farnell	9752838	-	B32562J6154K
C2	capacitor	150 nF 400 V	-	Farnell	9752838	-	B32562J6154K
C3	capacitor	1 μ F 35 V	0603	Farnell	1611920	-	GMK107BJ105KA-T
C11	capacitor	1 μ F 35 V	0603	Farnell	1611920	-	GMK107BJ105KA-T
C4	capacitor CPO NGO	330 pF 5 %	0603	-	-	-	-
C10	capacitor low ESR	1500 μ F 35 V	pitch = 5 mm	Farnell	1219477	Panasonic	EEUFM1V152L
C12	capacitor low ESR	1 μ F 35 V	0603	Farnell	1611920	-	GMK107BJ105KA-T
C13	capacitor	6.8 μ F 10 V	0805	Farnell	1572632	Kemet	C0805C106K8PAC-TU
C15	Y-CAP	Y-CAP 1 nF 250 V (AC)	-	-	3531971	Murata	DE1E3KX102MA5B
D1	diode bridge	MB6S	-	-	1621770	Multicomp	-
D2	TVS	P6KE400A	DO15	Farnell	1578842	-	-
D3	TVS	P6KE200A	DO15	Farnell	1017750	Multicomp	-
D4	diode fast	HER107	DO41	Farnell	9565191	Multicomp	-
D5	diode fast	HER107	DO41	Farnell	9565191	Multicomp	-
D6	Zener diode	BZV55-C30	SOD80C	Farnell	1081362RL	NXP	-
D10	diode Schottky	SB1H100	DO41	Farnell	9550364	Vishay	-
D11	Zener diode	BZV55-C22	SOD80C	Farnell	1097189	NXP	-
D12	diode standard	1n4148	SMD	Farnell	1469425	Vishay	-
D13	Zener diode	BZX384-B6V2	SOD-323	Farnell	1757832	NXP	BZX384-B6V2
F1	fuse	1 A 250 V	pitch = 5.08 mm	Farnell	1637535	Schurter	34.6915
IC1	SSL1523	SSL1523	-	-	-	NXP	SSL1523
IC2	opto coupler CTR 160 320 % isolation = class II	TCDT1124	-	Farnell	1045415	-	-
K1	connector	-	pitch = 5.08 mm	Farnell	1131853	Weidmuller	PM5.08/2/90
K2	connector	-	pitch = 5.08 mm	Farnell	1131853	Weidmuller	PM5.08/2/90
K3	connector	-	pitch = 2.54 mm	Farnell	1668357	Samtec	SSW-106-02-G-S-RA
K4	connector	-	pitch = 5.08 mm	Farnell	1131853	Weidmuller	PM5.08/2/90
L1	coil	1 mH - 13R105C	pitch = 2 E	Farnell	1710434	13R105C Murata	-
L10	coil	10 μ H 2.6 A	pitch = 5 mm	-	-	Wuerth	744772100

Table 2. Bill of materials ...continued

Q10	dual transistor PNP	BCM857DS	SC-74 (TSOP6) SOT457	Farnell	1757904	NXP	BCM857DS
Q11	transistor PNP	BC857	SMD	-	-	-	-
R1	resistor	33 Ω 2 W	-	Farnell	1565460	Welwyn	-
R2	resistor	100 Ω	0603	-	-	-	-
R3	resistor	6.8 kΩ	0603	-	-	-	MC34751
R4	resistor	220 kΩ	0603	-	-	-	-
R5	resistor	20 kΩ	0603	-	-	-	-
R6	resistor	47 kΩ	0603	-	-	-	-
R7	resistor	120 kΩ	0805	-	-	-	-
R8	resistor not wirewound	2.4 Ω	1206	-	-	-	-
R9	resistor not wirewound	2.4 Ω	1206	-	-	-	-
R10	current sense resistor not wirewound	1 Ω 1 W 1 %	-	Farnell	5383894	RCD Components	F1S 1R
R11	resistor	220 Ω 1 %	0603	-	-	-	-
R12	resistor	220 Ω 1 %	0603	-	-	-	-
R13	resistor	1 kΩ	0603	-	-	-	-
R17	resistor	1 kΩ 1 %	0603	-	-	-	-
R14	resistor	10 kΩ 1 %	0603	-	-	-	-
R15	resistor	10 kΩ 1 %	0603	-	-	-	-
R19	resistor	10 kΩ	0603	-	-	-	-
R20	resistor	10 kΩ	0603	-	-	-	-
R16	resistor	6.2 kΩ 1 %	0603	-	-	-	-
R18	variable resistor	4.7 kΩ	potentiometer leaded	Farnell	1227568	Tyco	CB10MV472ME
TX1	transformer	760871038	EE13	Wuerth	760871038	Wuerth	760871038

8. Transformer specification

Figure 6 shows the transformer schematic:

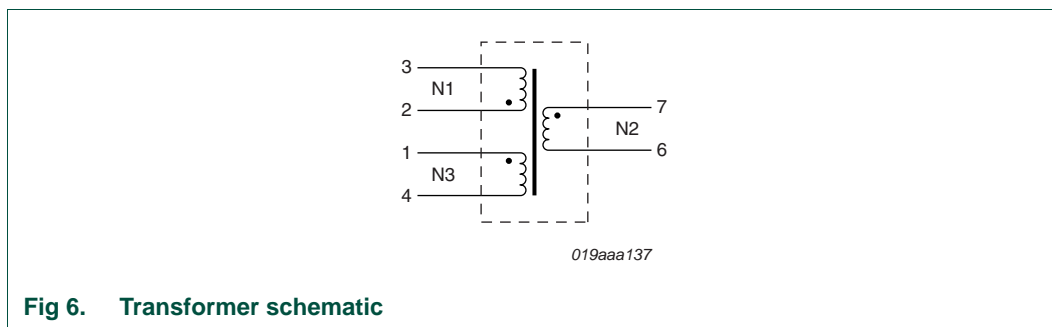

8.1 Winding specification

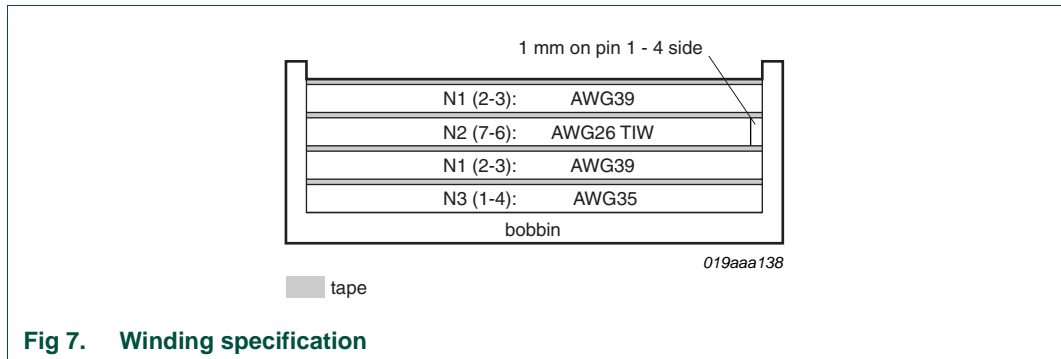

Table 3. Winding specification

Winding	Section	Ratio
Primary to secondary	N1 : N2	1 : 0.173
Primary to auxiliary	N1 : N3	1 : 0.204

8.2 Electrical characteristics

Table 4. Inductance

Section	Inductance
N1	1.85 mH ± 5 %
N2	56 µH
N3	75 µH

- Nominal frequency = 100 kHz
- $V_{breakdown}$ N1, N2 = 4 kV and N3, N2 = 4 kV
- Leakage inductance = 20 µH (short N2)

8.3 Core and bobbin

- Core: EE13/6/6 (3C90 or better)
- Air gap in centre leg
- Bobbin: for EE13/6/6 core; bobbin must be suitable for Class II isolation requirements.

8.4 Physical dimensions

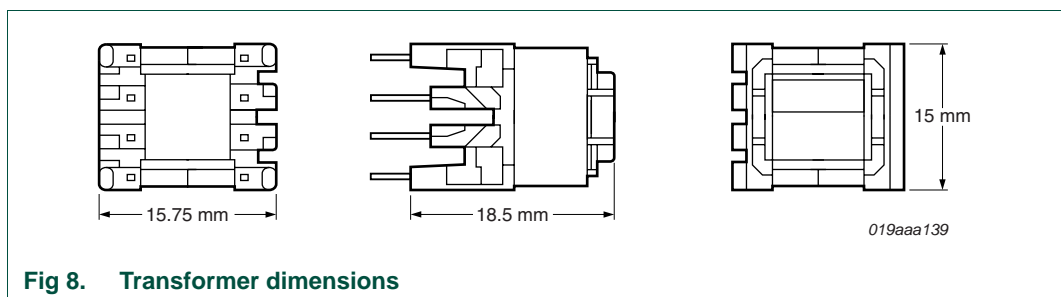

9. Appendix

9.1 Load curves

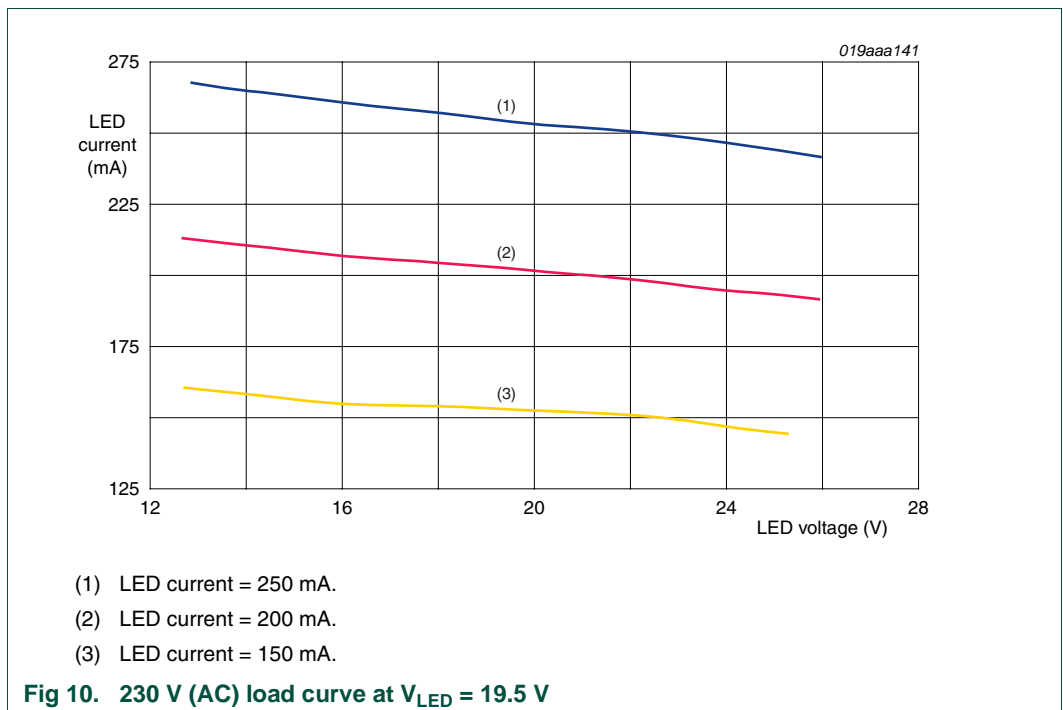
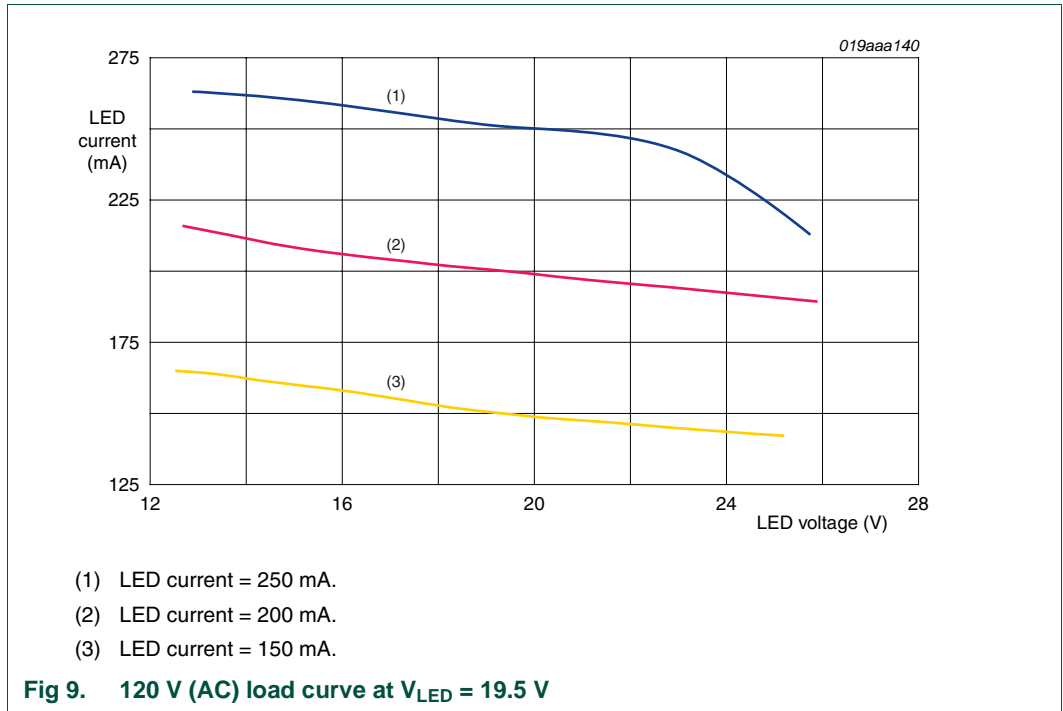

9.2 Efficiency curves

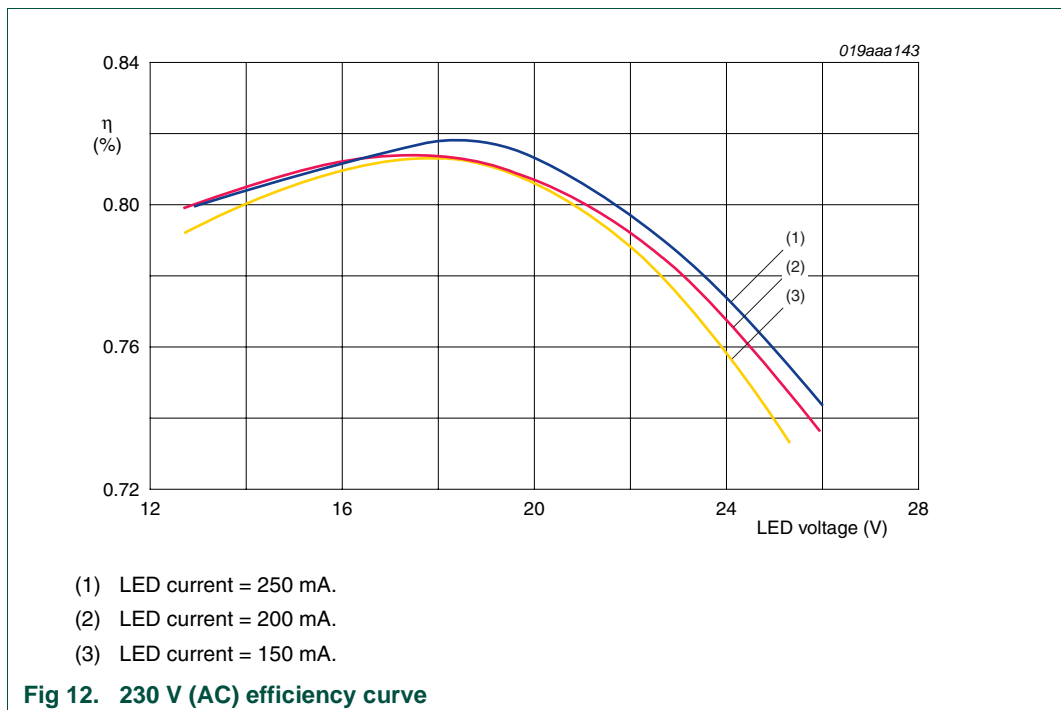
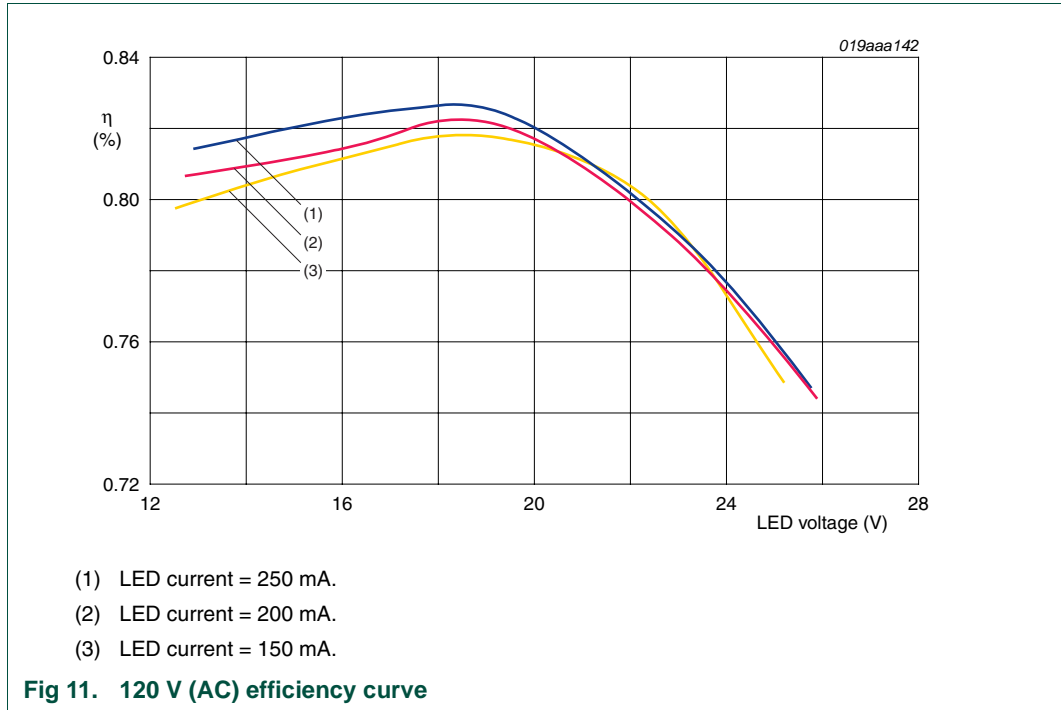

9.3 Input voltage dependency

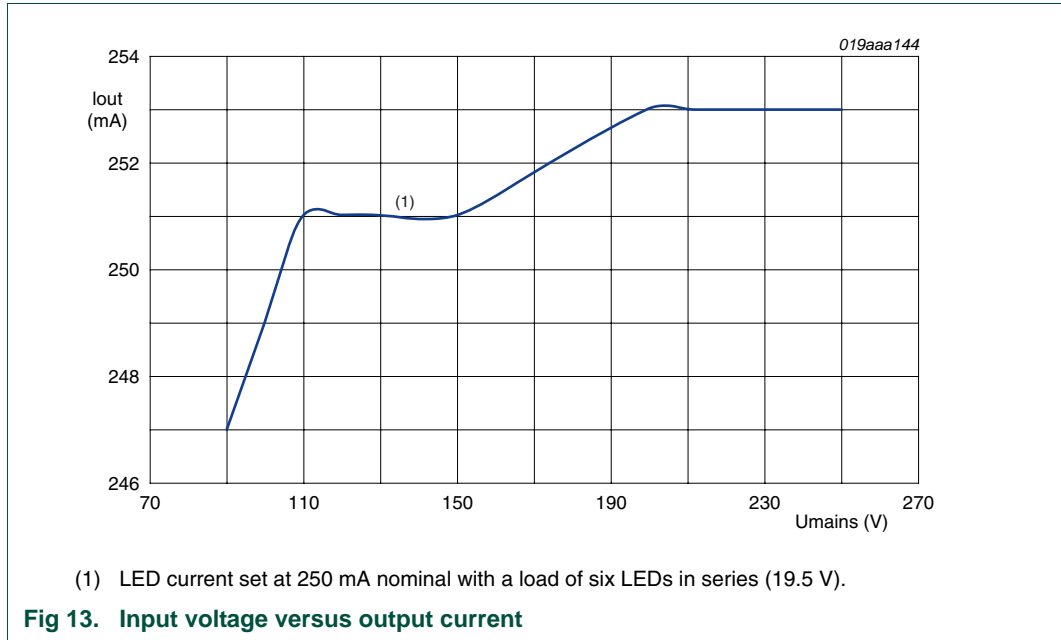

9.4 EMC requirements

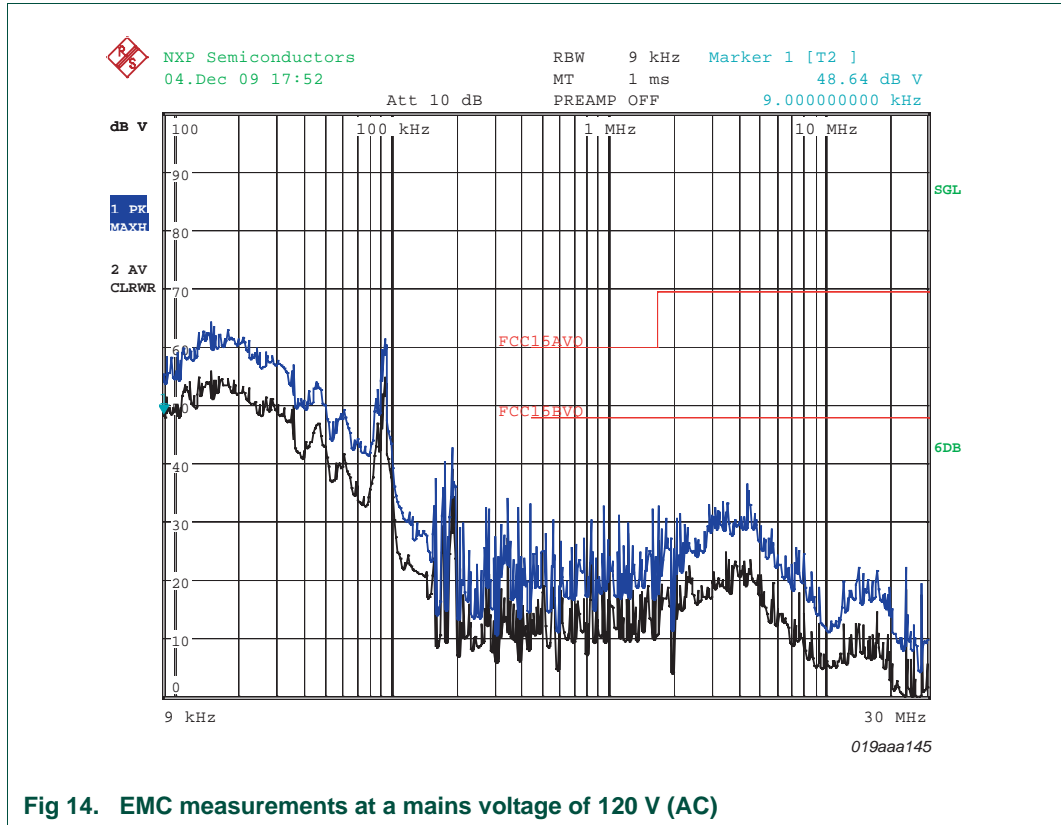

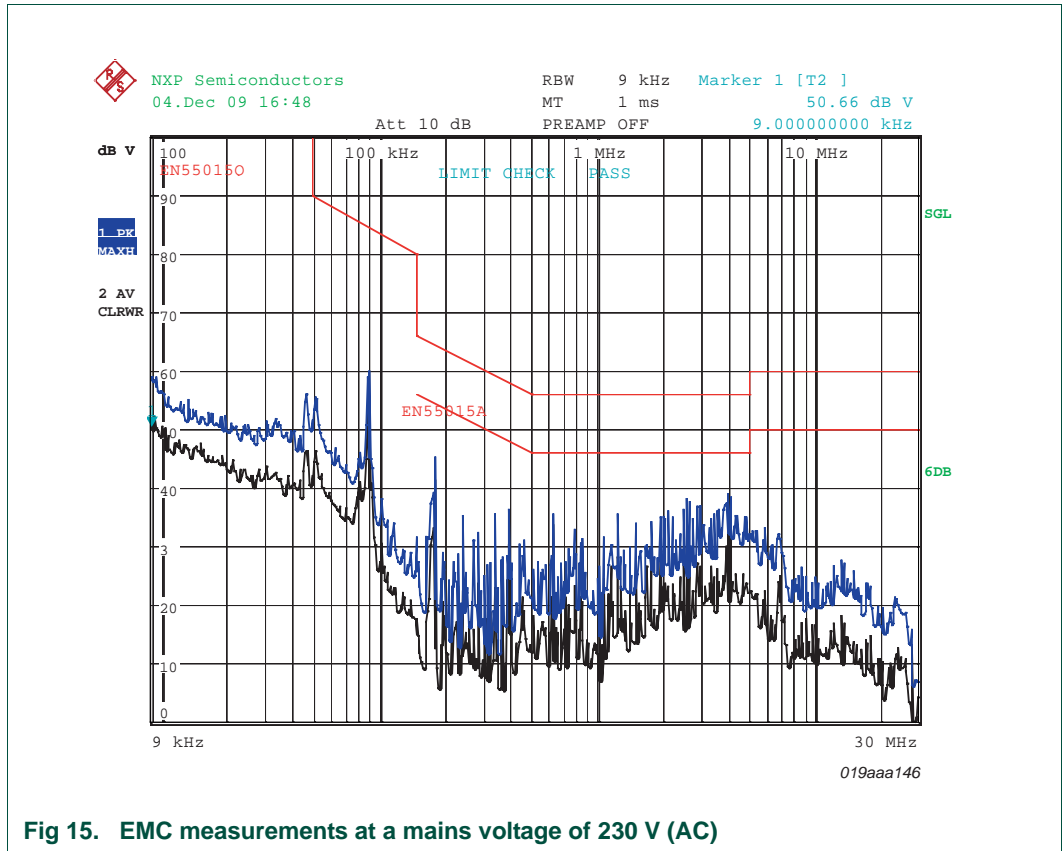

9.5 Mains conducted harmonics

Table 5. Mains conducted harmonics

Harmonic	230 V (AC) @ 50 Hz amplitude	120 V (AC) @ 60 Hz amplitude
1	100	100
2	0	0
3	11.0	8.1
4	0	0
5	12.5	14
6	0	0
7	11.7	2.7
8	0	0
9	7.7	1.2
10	0	0
11	5.0	2.1
12	0	0
13	7.4	2.4
14	0	00
15	3.0	2.4
16	0	0
17	7.6	1.5

Table 5. Mains conducted harmonics ...continued

Harmonic	230 V (AC) @ 50 Hz amplitude	120 V (AC) @ 60 Hz amplitude
18	0	0
19	1.1	3.4
20	0	0

Table 6. Total Harmonic Distortion and Power Factor

Parameter	230 V (AC) @ 50 Hz amplitude	120 V (AC) @ 50 Hz amplitude
THD	27.1	21.6
Power Factor (PF)	0.90	0.98

10. References

- [1] **TEA1761/TEA1762** — NXP GreenChip controllers for synchronous rectification.
- [2] **AN10754** — How to design an LED driver using the SSL2101 or SSL2102.
- [3] **SSL152x** — Datasheet - SMPS ICs for mains LED drivers.

11. Legal information

11.1 Definitions

Draft — The document is a draft version only. The content is still under internal review and subject to formal approval, which may result in modifications or additions. NXP Semiconductors does not give any representations or warranties as to the accuracy or completeness of information included herein and shall have no liability for the consequences of use of such information.

11.2 Disclaimers

Limited warranty and liability — Information in this document is believed to be accurate and reliable. However, NXP Semiconductors does not give any representations or warranties, expressed or implied, as to the accuracy or completeness of such information and shall have no liability for the consequences of use of such information.

In no event shall NXP Semiconductors be liable for any indirect, incidental, punitive, special or consequential damages (including - without limitation - lost profits, lost savings, business interruption, costs related to the removal or replacement of any products or rework charges) whether or not such damages are based on tort (including negligence), warranty, breach of contract or any other legal theory.

Notwithstanding any damages that customer might incur for any reason whatsoever, NXP Semiconductors' aggregate and cumulative liability towards customer for the products described herein shall be limited in accordance with the *Terms and conditions of commercial sale* of NXP Semiconductors.

Right to make changes — NXP Semiconductors reserves the right to make changes to information published in this document, including without limitation specifications and product descriptions, at any time and without notice. This document supersedes and replaces all information supplied prior to the publication hereof.

Suitability for use — NXP Semiconductors products are not designed, authorized or warranted to be suitable for use in life support, life-critical or safety-critical systems or equipment, nor in applications where failure or malfunction of an NXP Semiconductors product can reasonably be expected to result in personal injury, death or severe property or environmental damage. NXP Semiconductors accepts no liability for inclusion and/or use of NXP Semiconductors products in such equipment or applications and therefore such inclusion and/or use is at the customer's own risk.

Applications — Applications that are described herein for any of these products are for illustrative purposes only. NXP Semiconductors makes no representation or warranty that such applications will be suitable for the specified use without further testing or modification.

Customers are responsible for the design and operation of their applications and products using NXP Semiconductors products, and NXP Semiconductors accepts no liability for any assistance with applications or customer product

design. It is customer's sole responsibility to determine whether the NXP Semiconductors product is suitable and fit for the customer's applications and products planned, as well as for the planned application and use of customer's third party customer(s). Customers should provide appropriate design and operating safeguards to minimize the risks associated with their applications and products.

NXP Semiconductors does not accept any liability related to any default, damage, costs or problem which is based on any weakness or default in the customer's applications or products, or the application or use by customer's third party customer(s). Customer is responsible for doing all necessary testing for the customer's applications and products using NXP Semiconductors products in order to avoid a default of the applications and the products or of the application or use by customer's third party customer(s). NXP does not accept any liability in this respect.

Export control — This document as well as the item(s) described herein may be subject to export control regulations. Export might require a prior authorization from national authorities.

Evaluation products — This product is provided on an "as is" and "with all faults" basis for evaluation purposes only. NXP Semiconductors, its affiliates and their suppliers expressly disclaim all warranties, whether express, implied or statutory, including but not limited to the implied warranties of non-infringement, merchantability and fitness for a particular purpose. The entire risk as to the quality, or arising out of the use or performance, of this product remains with customer.

In no event shall NXP Semiconductors, its affiliates or their suppliers be liable to customer for any special, indirect, consequential, punitive or incidental damages (including without limitation damages for loss of business, business interruption, loss of use, loss of data or information, and the like) arising out of the use of or inability to use the product, whether or not based on tort (including negligence), strict liability, breach of contract, breach of warranty or any other theory, even if advised of the possibility of such damages.

Notwithstanding any damages that customer might incur for any reason whatsoever (including without limitation, all damages referenced above and all direct or general damages), the entire liability of NXP Semiconductors, its affiliates and their suppliers and customer's exclusive remedy for all of the foregoing shall be limited to actual damages incurred by customer based on reasonable reliance up to the greater of the amount actually paid by customer for the product or five dollars (US\$5.00). The foregoing limitations, exclusions and disclaimers shall apply to the maximum extent permitted by applicable law, even if any remedy fails of its essential purpose.

11.3 Trademarks

Notice: All referenced brands, product names, service names and trademarks are the property of their respective owners.

12. Tables

Table 1.	Specification	3
Table 2.	Bill of materials	10
Table 3.	Winding specification	12
Table 4.	Inductance	12
Table 5.	Mains conducted harmonics	16
Table 6.	Total Harmonic Distortion and Power Factor ..	17

continued >>

13. Figures

Fig 1.	Demo board top	4
Fig 2.	Demo board bottom	4
Fig 3.	Demo board connection diagram	5
Fig 4.	Mains current (C2), V_{CC} (C1), bulk capacitor input voltage (C3) and the mains voltage (C4)	6
Fig 5.	Demo board schematic	9
Fig 6.	Transformer schematic	11
Fig 7.	Winding specification	12
Fig 8.	Transformer dimensions	12
Fig 9.	120 V (AC) load curve at $V_{LED} = 19.5$ V	13
Fig 10.	230 V (AC) load curve at $V_{LED} = 19.5$ V	13
Fig 11.	120 V (AC) efficiency curve	14
Fig 12.	230 V (AC) efficiency curve	14
Fig 13.	Input voltage versus output current	15
Fig 14.	EMC measurements at a mains voltage of 120 V (AC)	15
Fig 15.	EMC measurements at a mains voltage of 230 V (AC)	16

continued >>

14. Contents

1	Introduction	3
1.1	General description	3
2	Specification	3
3	Demo board views	4
4	Demo board connections	5
4.1	Connecting the demo board:	5
5	Functional description	5
6	Board system optimization	7
6.1	Changing the output current and LED current .	7
6.2	Changing the output ripple current	7
6.3	Changing the load curve	7
7	Board schematic	9
7.1	Bill of materials (BOM)	10
8	Transformer specification	11
8.1	Winding specification	12
8.2	Electrical characteristics	12
8.3	Core and bobbin	12
8.4	Physical dimensions	12
9	Appendix	13
9.1	Load curves	13
9.2	Efficiency curves	14
9.3	Input voltage dependency	15
9.4	EMC requirements	15
9.5	Mains conducted harmonics	16
10	References	17
11	Legal information	18
11.1	Definitions	18
11.2	Disclaimers	18
11.3	Trademarks	18
12	Tables	19
13	Figures	20
14	Contents	21

Please be aware that important notices concerning this document and the product(s) described herein, have been included in section 'Legal information'.

© NXP B.V. 2010.

All rights reserved.

For more information, please visit: <http://www.nxp.com>

For sales office addresses, please send an email to: salesaddresses@nxp.com

Date of release: 3 August 2010

Document identifier: UM10406